

TANDEM DUAL GOOSENECK DUMP

G.V.W.R.	25,900#	AXLES	Two 10,000# Dual Wheel Oil Bath Electric Brake
G.A.W.R. (E.L. Axle)	10,000#	SUSPENSION	Multi-Leaf Slipper Spring w/ Equalizer
COUPLER	2-5/16" Ball Adjustable Pipe	TIRE	ST235/85R16 Load Range E
SAFETY CHAINS	3/8" Grd. 70 w/Safety Latch Hook (2 e.a.)	WHEEL	16 X 6 Dual 8 Bolt
JACKS	Two 12,000# Dropleg Jacks (Bolted On)	FLOOR	10 Gauge Smooth Steel
NECK	12" Channel	LIGHTS	D.O.T. Stop, Tail, Turn and Clearance
FRAME	12" X 16# I-Beam	ELEC. PLUG	7-Way RV
FRAME CROSSMEMBERS	8" Channel	FINISH (PREP)	Acid Etched w/White Phosphorus, Undercoated w/Panther 813 & Two Coats Primer
BED CROSSMEMBERS	3" Channel	FINISH	Painted w/2 Coats High Solid <i>Supreme</i> Acrylic Automotive Grade Enamel, and Finstriped
BED LONG SILS	8" Channel		
SIDE RAILS	3" X 5" Angle		

- Complete Break-A-Way System w/ Charge Line
- Heavy Duty 10 Gauge Floor
- 48" Sides w/ Formed Channel Supports
- Spare Mount
- Self Contained Electric Hydraulic Scissor Lift
- Lockable Control Unit
- 45 Degree Dump Angle
- 4-5/8" D-Rings Inside Bed
- Double Rear Gates w/ Cam Latch
- Removable Header Across Rear
- Double 1/2" Tie Rods On All 4 Sides
- Fully Enclosed Pump & Battery Box Between Gooseneck Uprights

25DU-16

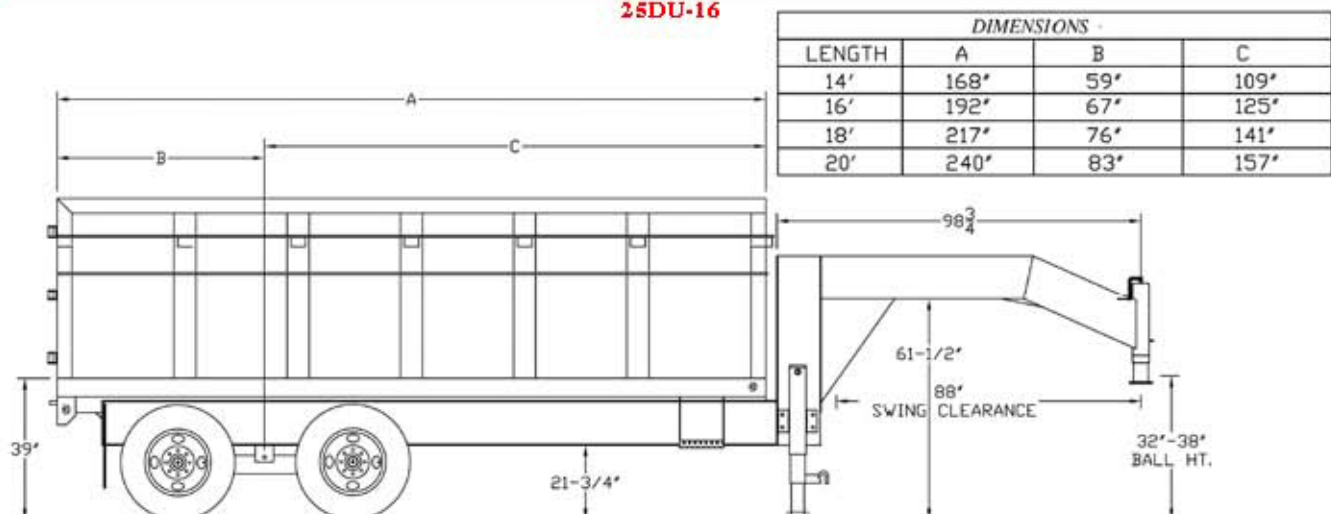

TRAILER WEIGHTS & CAPACITIES

LENGTH	EMPTY WEIGHT	PAYLOAD	BOX CAPACITY
16'	7,790#	18,200#	18.63 Cubic Yards
18'	8,120#	18,200#	21.98 Cubic Yards
20'	8,560#	17,340#	23.7 Cubic Yards

PRICING

MODEL #	DESCRIPTION	
PRICE		
25DU-16	92" X 16' Tandem Dual Gooseneck Dump	

OPTIONS

Dual 2-Speed Landing Gear Jack (150K)	
16" Spare Tire & Wheel	
Sides w/ Stake Pockets & Rubrail (Flatbed)	
Roll Top w/Side Flaps	

Prices Effective August 1, 2006

©2006 Copyright by Big Tex Trailer Manufacturing, Inc.